

# UD2600

2008 MODEL YEAR



Distributed by

Nissan Diesel America, Inc.



\*UD2600 shown here with dealer installed optional equipment.

WHEELBASES	E	H	K	M	N	R	S
GVWR (lb.)	25,995	25,995	25,995	25,995	25,995	25,995	25,995
Chassis Weight (lb.)	9,525	9,610	9,720	9,830	9,965	9,975	10,040
Front (lb.)	5,855	5,985	6,070	6,115	6,185	6,160	6,205
Rear (lb.)	3,670	3,625	3,650	3,715	3,780	3,815	3,835
Gross Payload (lb.)*	16,470	16,385	16,275	16,165	16,030	16,020	15,955
Wheelbase (in.) ** WB	150.39	177.17	192.91	208.66	222.44	238.19	253.94
Cab-to-Rear Axle (in.) CA	118.30	145.00	160.80	176.50	190.30	206.10	221.80
Rear Overhang (in.) RO	44.90	72.80	77.00	88.60	102.40	110.20	114.20
Overall Length (in.) OL	245.70	300.40	320.30	347.60	375.20	398.80	418.50
Typical Body Lengths (ft.)***	14/16	16/18	18/20	20/22	24/26	26/28	28/30
Turning Radius (ft.)	21.30	25.40	27.40	29.40	31.20	32.80	35.00

\*Gross payload capacity equals GVWR minus chassis weight. Installation of specialized equipment or bodies may require frame reinforcement. \*\*Wheelbase selection should be based on specific weight distribution. \*\*\*Typical body lengths assume water level load (no specific consideration for driver, passengers, or fuel) to maximize GVWR. Addition of ancillary equipment such as lift gates and refrigeration units not considered in calculations.

## ENGINE

	MD230* - 24 Valve
	Turbo/Intercooled Diesel
	In-line 6 cylinder, Direct-injection
Horsepower	230 hp @ 2,500 rpm
Torque	506 lb. ft. @ 1,500 rpm
Displacement	469 in. <sup>3</sup> (7.684 L)
Cylinder Liner	Dry, replaceable
Air Compressor	14.1 CFM @ 2,600 engine rpm (nominal)
Fuel System	Electronically controlled common rail system
Air Cleaner	11 in., paper filter type (DONALDSON)
Cold Starting Aid	Automatic electric glow plug
Fan	Viscous type drive

\*MD230 (J08E-TE) is a vendor engine manufactured for Nissan Diesel Motor Company.

## FRONT AXLE

Rated Axle Capacity	9,480 lb.
Axle Type	"I" Beam
Suspension	Semi-elliptic leaf springs
Shock Absorbers	Telescopic type

## TRANSMISSION

Ratios	STD		OPTION	
	Nissan Diesel, MLS63B		Allison, 2200RDS	
	Manual, 6 forward speeds & 1 reverse synchromesh on 2nd through 6th gears		Automatic 5 forward speeds & 1 reverse	
1st	6.72		3.10	
2nd	4.03		1.81	
3rd	2.30		1.41	
4th	1.44		1.00	
5th	1.00		0.71	
6th	0.74		—	
Rev.	6.12		4.49	
R/A Ratio	5.14	5.57 <sup>STD</sup>	5.14 <sup>STD</sup>	5.57
Engine rpm @ 65 mph				
w/ 11R22.5	2,080	2,250	2,000*	2,165*

\*Approximate engine rpm only. Allison will provide a performance scan by application on request.

## CLUTCH

Hydraulic clutch with air assist  
13.8 in. cerametallic friction material  
Standard clutch wear indicator

## STEERING

Integral power steering, gear driven pump  
Steering Column Tilt & telescopic type

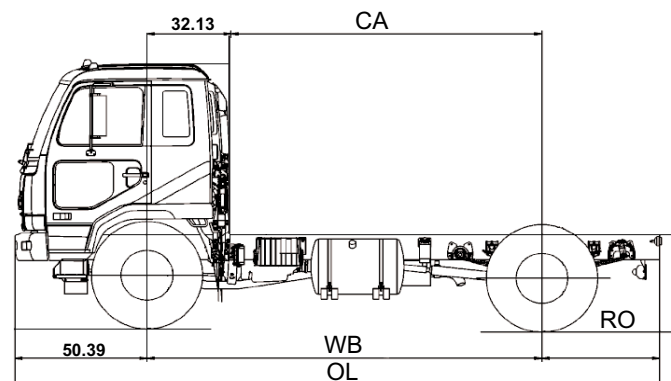
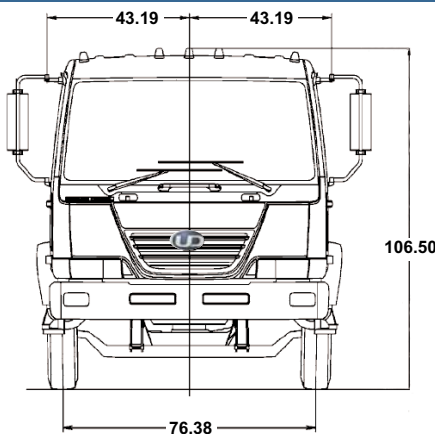

# UD2600

2008 MODEL YEAR



# TRUCKS

Distributed by  
Nissan Diesel America, Inc.

## REAR AXLE

Rated Axle Capacity 18,080 lb.  
Axle Type Full-floating banjo housing  
Suspension Semi-elliptic leaf springs with auxiliary springs

## WHEELS & TIRES

Tires Front: Single, highway tread  
Rear: Dual, highway tread  
11R22.5 - 14PR (tubeless radial)  
Wheels Steel disc type, 8 hole,  
7.50 x 22.5 in., offset 6.38 in.

## BRAKE SYSTEM

Service Brakes Anti-lock Braking System  
Dual line, air-over-hydraulic brake system  
Front Internal expanding, two leading shoe,  
self-adjusting drum brakes  
Drum diameter x lining width x lining  
thickness: 15.75 x 4.72 x 0.59 in.  
Rear Internal expanding, dual two leading shoe,  
self-adjusting drum brakes  
Drum diameter x lining width x lining  
thickness: 15.75 x 6.10 x 0.59 in.  
Air Tanks Supply: 641 in.<sup>3</sup>  
Front service: 549 in.<sup>3</sup>  
Rear service: 641 in.<sup>3</sup>  
Total: 1,831 in.<sup>3</sup>  
Air Dryer Standard  
Parking Brake Hand brake lever activating drum at  
rear of transmission

## EXHAUST BRAKE

Electrically controlled, pneumatically  
activated butterfly valve in exhaust pipe

## CHASSIS FRAME

Ladder type, channel section side rails

Dimensions (in.) \* 9.84 x 3.15 x 0.31  
Assembled Width (in.) 33.9  
Section Modulus (in.<sup>3</sup>) \*\* 26.6  
Yield Strength (psi) 51,200  
RBM (in.-lb.) 1,362,000

\*Height x Flange Width x Thickness \*\*Measured at back-of-cab, specifications  
based on complete chassis (both rails)

## FUEL TANK

Round fuel tank, mounted to left side  
Capacity - 50 gallons

## CAB

Forward control, steel construction, tilting  
cab. Cab suspension w/ shock absorbers  
Air Conditioner Standard  
Cab Glass Windshield, tinted laminated, 2,314 in.<sup>2</sup>  
Cruise Control Standard  
Door Locks Driver & passenger, electric control  
Door Vent Window Driver, ventilating type  
Driver's Seat Height & seat back angle adjustable, with  
air suspension. Cloth cover, high back type  
Floor Mats Standard  
Keyless Entry Standard  
Passenger Seat Seat back angle adjustable  
Cloth cover, high back type  
Seat Belts Driver & passenger, 3-point ELR type  
Rearview Mirrors West coast type, 6.5 x 11 in. with  
Convex type, 5.8 x 4.3 in.  
Steering Column Tilt & telescopic type  
Sun Visors Driver & passenger  
Windows Driver & passenger, electric control  
Windshield Wipers Dual, electric-driven, intermittent & 2 speed

## ELECTRICAL EQUIPMENT

Back-up lights  
Cigar lighter  
Clearance, identification & position lights  
Day-time running lights  
Halogen headlights, 2 lamps  
Interior and map light  
License light  
Side turn signal lights  
Stop/tail lights  
Turn signal/hazard lights  
Power outlet - 12 volt

## INSTRUMENTS

### Meters & Gauges

Air pressure gauges  
Coolant temperature gauge  
Fuel gauge  
Speedometer, odometer & trip meter  
Tachometer

### Warning & Indicator Lights & Buzzers

ABS warning light  
Alternator low charge warning light  
Automatic Transmission:  
- Check warning light  
- Range inhibited warning light  
- High temperature fluid warning  
light & buzzer  
Engine glow plug indicator light  
Cab lock warning light & buzzer  
Engine control system warning light  
External air restriction indicator  
Exhaust brake indicator light  
Hazard warning flasher  
High beam indicator light  
Low air pressure warning light & buzzer  
Low brake fluid level warning light  
& buzzer  
Low coolant level & overheating  
warning light & buzzer  
Low oil pressure warning light  
Parking brake indicator light  
Sedimentor warning light  
Service brake warning light & buzzer  
Turn signal indicator lights  
Warning lights with burnt-out bulb  
check function  
Backup alarm  
DPF warning/indicator lights

## OTHER OPTIONS

AM/FM stereo radio with CD  
Block heater  
Center console/ third seat  
Rear wheel parking brake  
Heated mirror  
Rear engine PTO WB "E"  
Rear traction tires

All illustrations, specifications and descriptions in this specification are based on the  
latest product information available at the time of this publication. The right is  
reserved to make changes in price, materials, equipment, design, specifications, dia-  
grams and models, and to discontinue models of equipment at any time, without  
notice and without incurring any obligation whatsoever. For more information on  
additional options and accessories, contact NISSAN DIESEL AMERICA, INC.

Manufacturer:  
NISSAN DIESEL MOTOR CO., LTD.  
Saitama, Japan

Distributor:  
NISSAN DIESEL AMERICA, INC.  
P.O. Box 152034  
Irving, Texas 75015-2034  
www.udtrucks.com